

SITE PLAN DIAGRAM

1/16" = 1'-0"
 LOT AREA 25' X 100'-5" = TOTAL LOT AREA = 2,510.5 SF
 LOT COVERAGE

(ZR 96-102) R8 IN SPECIAL CLINTON DISTRICT /SUB DISTRICT AREA A "PRESERVATION AREA"
 MAX LOT COVERAGE FOR "INTERIOR LOT" IS %60 X(25' X100'-5") = 2510.58 SF) = 1,506.3 SF MAX ALLOWED.
 PROPOSED LOT COVERAGE: (25' X 55'-5 5/8" + 11'-2" X 10'-4") = 1,387 SF = 55% < 65% COMPLIES.

YARD REGULATIONS

(ZR 96-103) MIN DEPTH OF REAR YARD EQUIVALENT MIN. 30FT FOR INTERIOR LOT COMPLIES
 (ZR 23-462 C) SIDE YARD IN R8 DISTRICT IS NOT REQUIRED COMPLIES

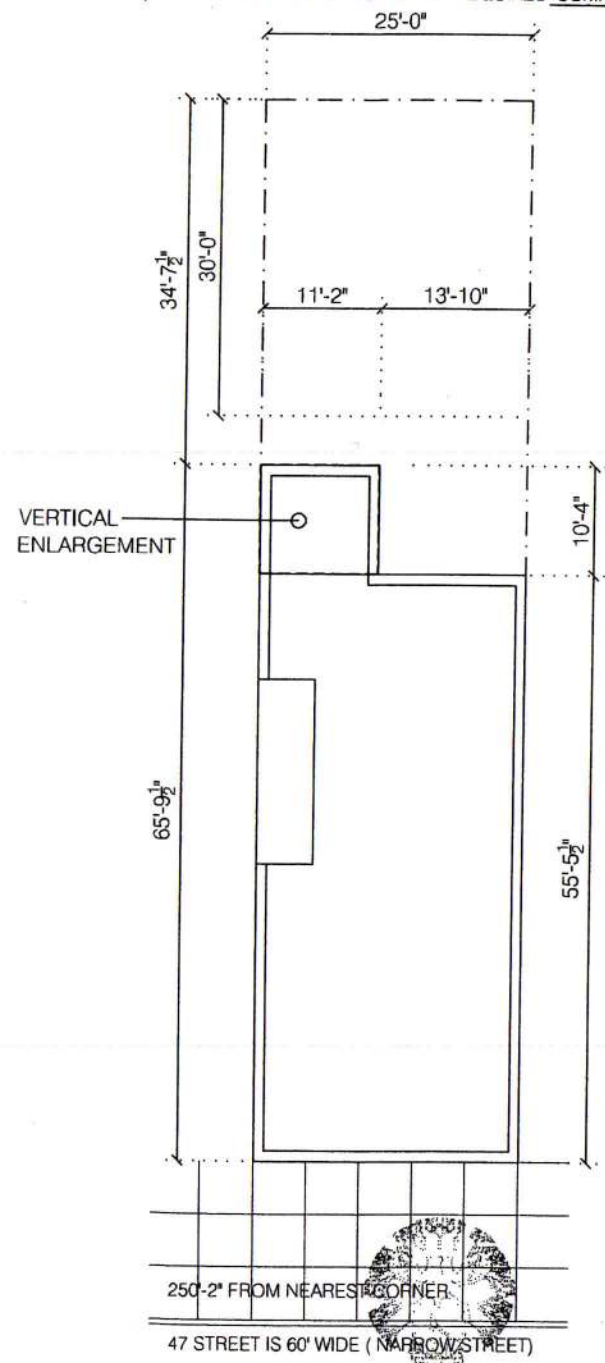

STREET TREE PLANTING
 (ZR 26-41)(ZR 33-03)QUALITY HOUSING ONE
 STREET TREE SHALL BE PROVIDED FOR EVERY 25 FEET OF A STREET FRONTAGE.
 1 (ONE) TREE IS PROVIDED

SECTION DIAGRAM

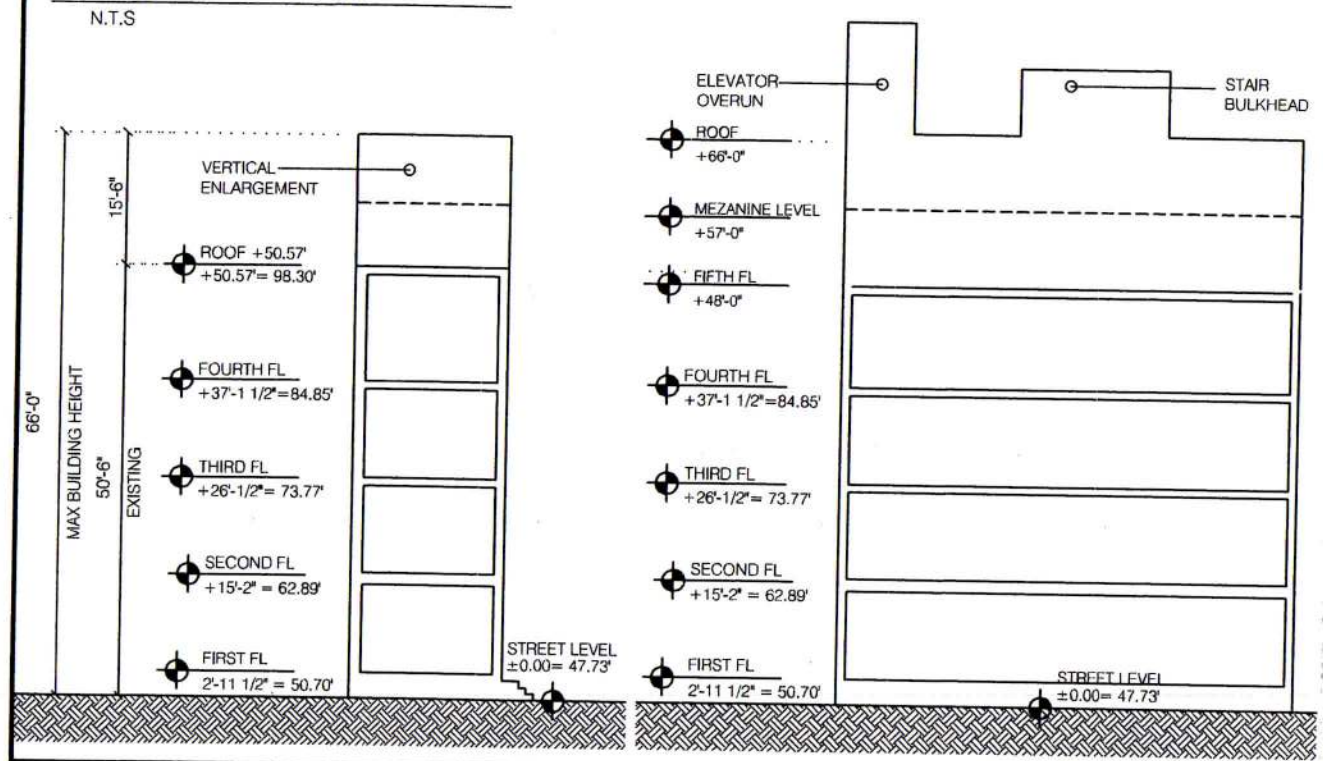

AXONOMETRIC DIAGRAM

N.T.S.
HEIGHT & SET BACK REGULATIONS
 ZR 96-104 (c) MAXIMUM BUILDING HEIGHT IS 66' OR SEVEN STORIES WHICH EVER IS LESS. MAX PROPOSED HEIGHT IS 66' COMPLIES
 ZR 96-104 (a) STREET WALL LOCATION: THE EXISTING & PROPOSED STREET WALL SHOULD BE ALIGNED WITH ADJACENT BUILDING STREET WALL COMPLIES

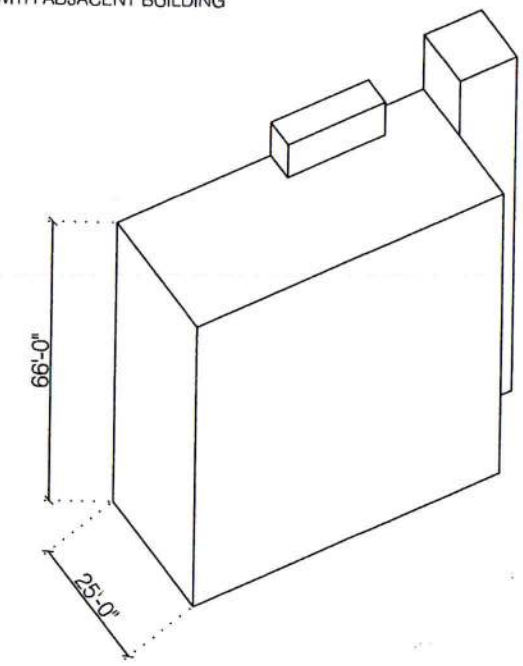

ZD1 Zoning Diagram
 Must be typewritten.

Orient and affix BIS job number label here

Submitted to resolve objections stated in a notice of intent to revoke issued pursuant to rule 101-15.
 Yes No

Location Information	
House No(s)	343
Street Name	WEST 47 STREET
	NEW YORK NY 10036
Borough	MANHATTAN
Block	1038
Lot	11
BIN	1025089

Falsification of any statement is a misdemeanor and is punishable by a fine or imprisonment, or both. It is unlawful to give to a city employee, or for a city employee to accept, any benefit, monetary or otherwise, either as a gratuity for properly performing the job or in exchange for special consideration. Violation is punishable by imprisonment or fine or both. I understand that if I am found after hearing to have knowingly or negligently falsified or allowed to be falsified any certificate, form, signed statement, application, report or certification of the correction of a violation required under the provisions of this code or of a rule of any agency, I may be barred from filing further applications or documents with the Department.

Name (please print)
 YOSEF MELAMED
 Signature _____ Date 07-30-14



P.E./R.A. Seal - (apply seal, then sign and date over seal)

Internal Use Only

BIS Doc # _____

PLAN EXAMINER SIGN AND DATE

